



Erasmus+



ERASMUS+

A Lutin – Wetzlar projectwork
Autumn 2016

ALL MEMBERS



PROJECT DESCRIPTION

- ▶ The main goal is to make a **car**, which runs on **compressed air**
- ▶ All students form **4 teams**, each team is divided into **4 separate groups** (CAD, CNC, Workshop, Documentation)
- ▶ There is also a separate **Videodocumentation group**

OUR TEAMS

TEAM 1



TEAM 2



OUR TEAMS

TEAM 3



TEAM 4



CAD GROUPS



**Tomáš Petrovský
Steven Schroth
Artur Pohlodko
Karsten Karsten
Michal Procházka
Petr Jalůvka
Maxmilian Mappes
Jonas Peipert
Tomáš Sotorník
Jakub Kouřil**



THEIR TASK

Their task is to create a model of the **front wheels**, assembled cars and accesories.



FINISHED DRAWINGS

1

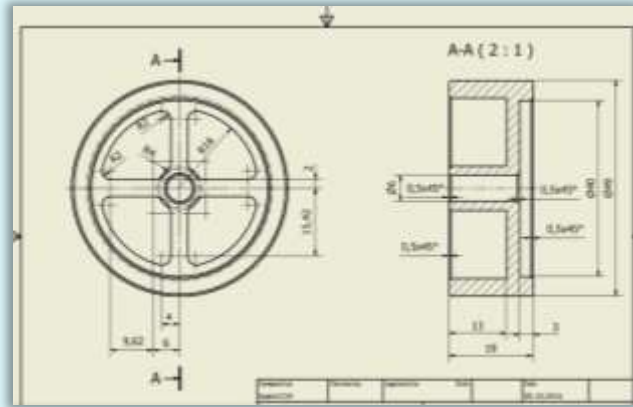

2

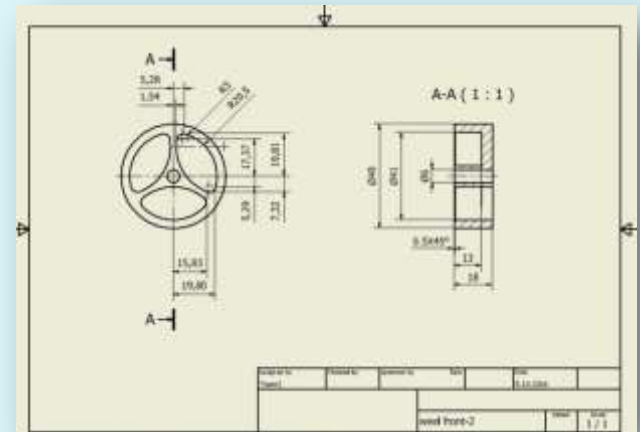

3

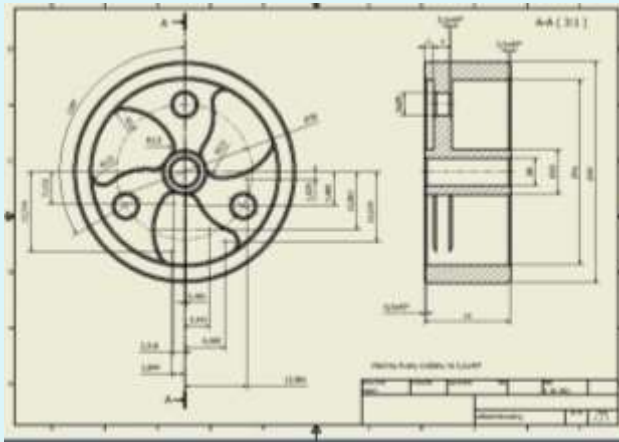

4

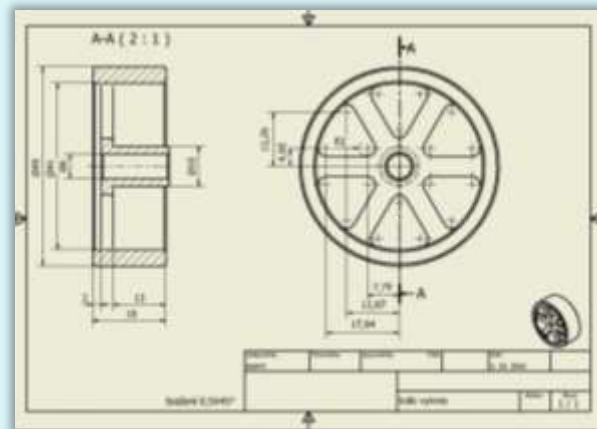

CNC GROUPS



**Michael Tichý
Nicolas Gatz
Ondřej Voráč
Tomáš Dostál
Jonas Feyle
Zdeněk Müller
Daniel Schwiddesessen
Daniel Haselman
Jan Pišťák
Paul Benner**



THEIR TASK

- ▶ Their task is to create a CNC program for milling the wheels.



FINISHED WHEELS

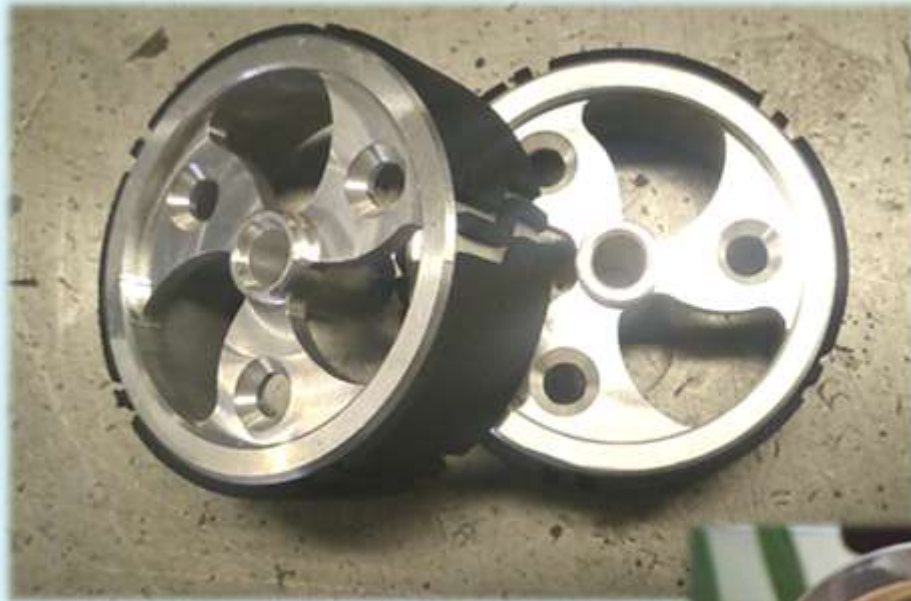

WORKSHOP GROUPS



**Matěj Škoda
Philipp Jung
Michal Zbořil
Pieter Rink
Jakub Dvořák
Niklas Oberheide
Adam Glauder
Max Hubl
Philipp Reiß**



THEIR TASK

- ▶ Their task is to create accessories for the cars and put everything together



DOCUMENTATION GROUPS

1



Starošík, Karel
Hofmann, Eric
Švéda, Michal
Prick, Felix
Marek, Tomáš
Klein, Christopher
Hedrich, Lukas

2



3



4



THEIR TASK

- ▶ Their task is to record the work of other groups. They have to create a presentation with photos and descriptions of work.



FINISHED DOCUMENTS



VIDEODOCUMENTATION GROUP



Václav Metelka

Stanislav Šesták

Eduard Wolf



THEIR TASK

- ▶ Their task was to create a video about the projectwork.

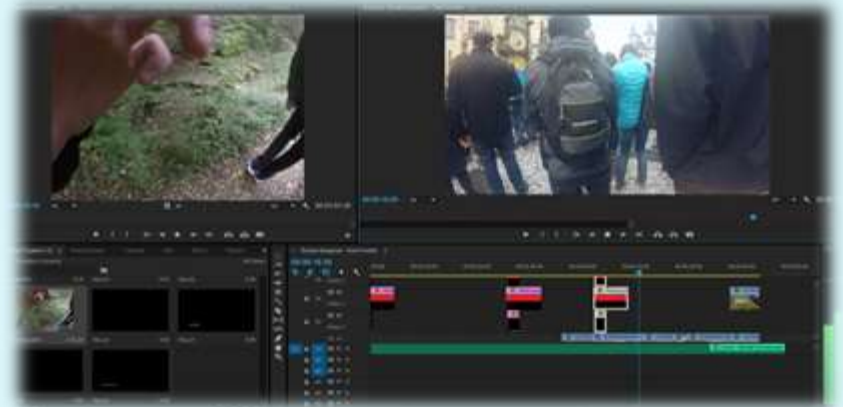

FINISHED CARS

TEAM 1



TEAM 2

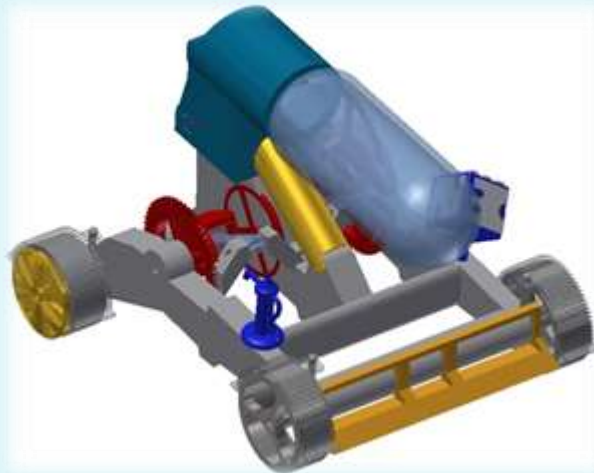

FINISHED CARS

TEAM 3

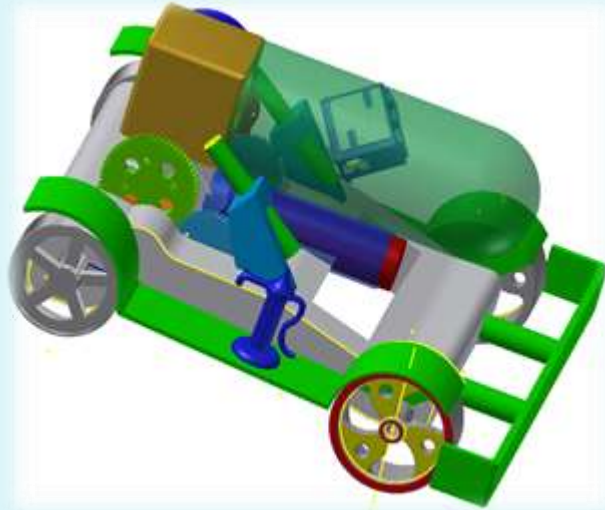

TEAM 4

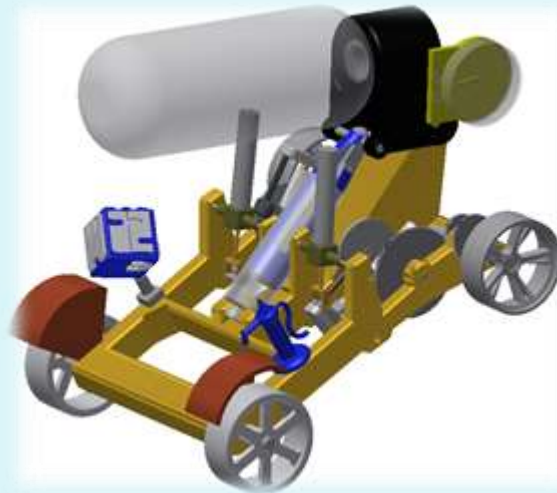

THANK YOU FOR YOUR
ATTENTION!



Erasmus+

ANNOUNCEMENT

- ▶ This project has been funded with support from the European Commission. This publication [communication] reflects the views only of the author, and the Commission cannot be held responsible for any use which may be made of the information contained therein.



Erasmus+