



Erasmus+

Erasmus+

a Lutin – Wetzlar project

2015

Our photo



Our task

- Our task is to create a car model using an already existing base (engine + chassis).
- We have to design our own car body, wheel covers and logos.
- Students form four teams, each team is divided into four different groups
 - CAD
 - CNC
 - Workshop
 - Documentation

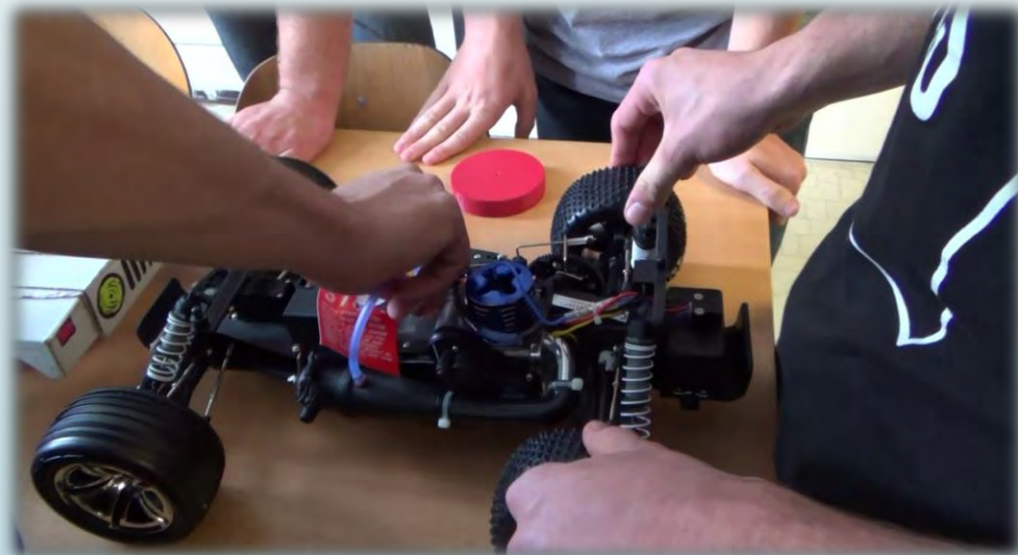



CAD Group

FOTO:

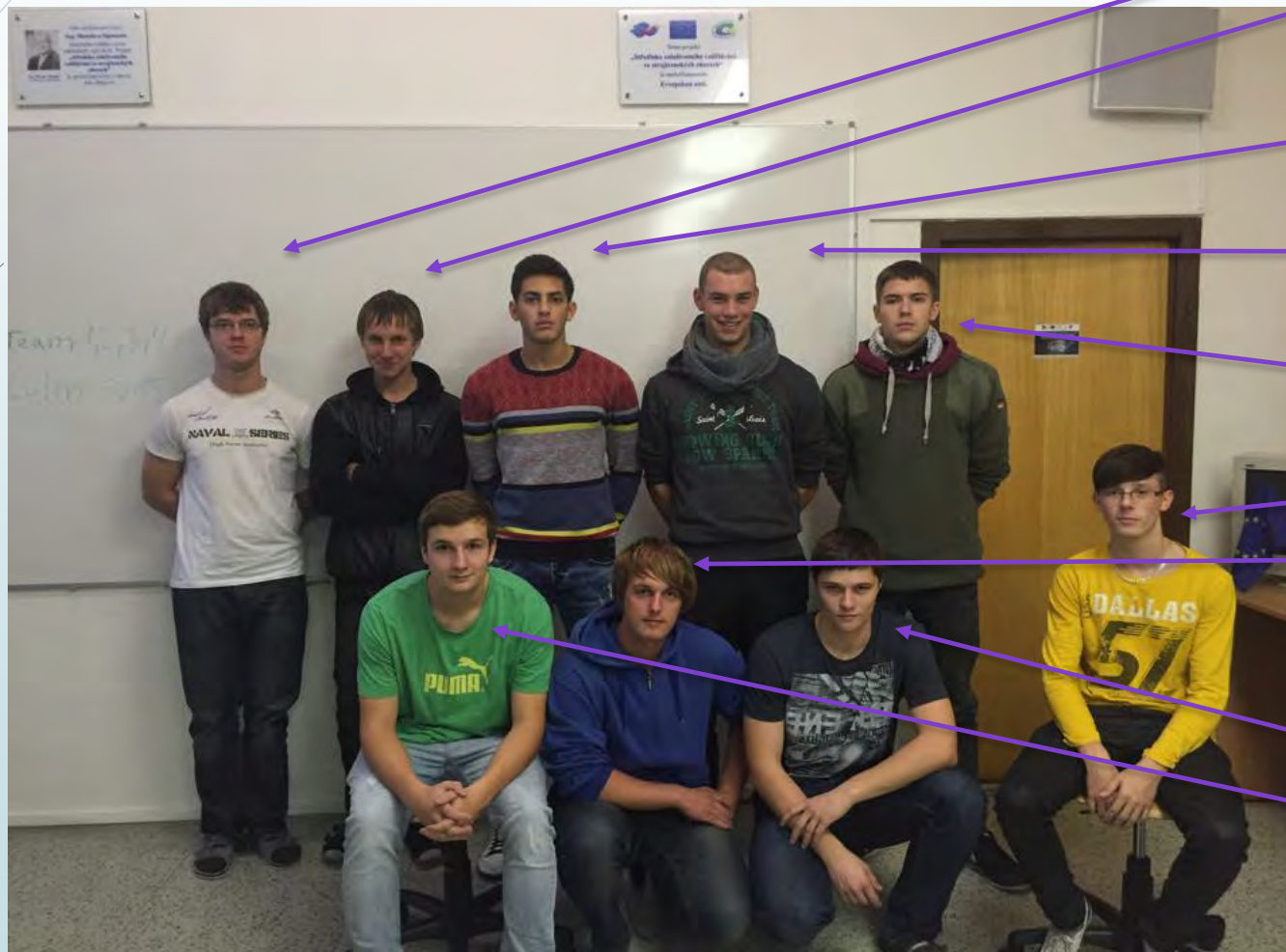

T. Sotorník
J. Sotorník
T. Jeřábek
H. Aktas
A. Heinz
D. Nixdorf
F. Halfmann
C. Köhler
M. Procházka
D. Král
P. Kugler
K. Klimowitsch
J. Bém
J. Wagner

Their tasks

- Their task is to make a 3D model and a technical sheet of every custom part (wheel covers, car body, logos, complete assembly)

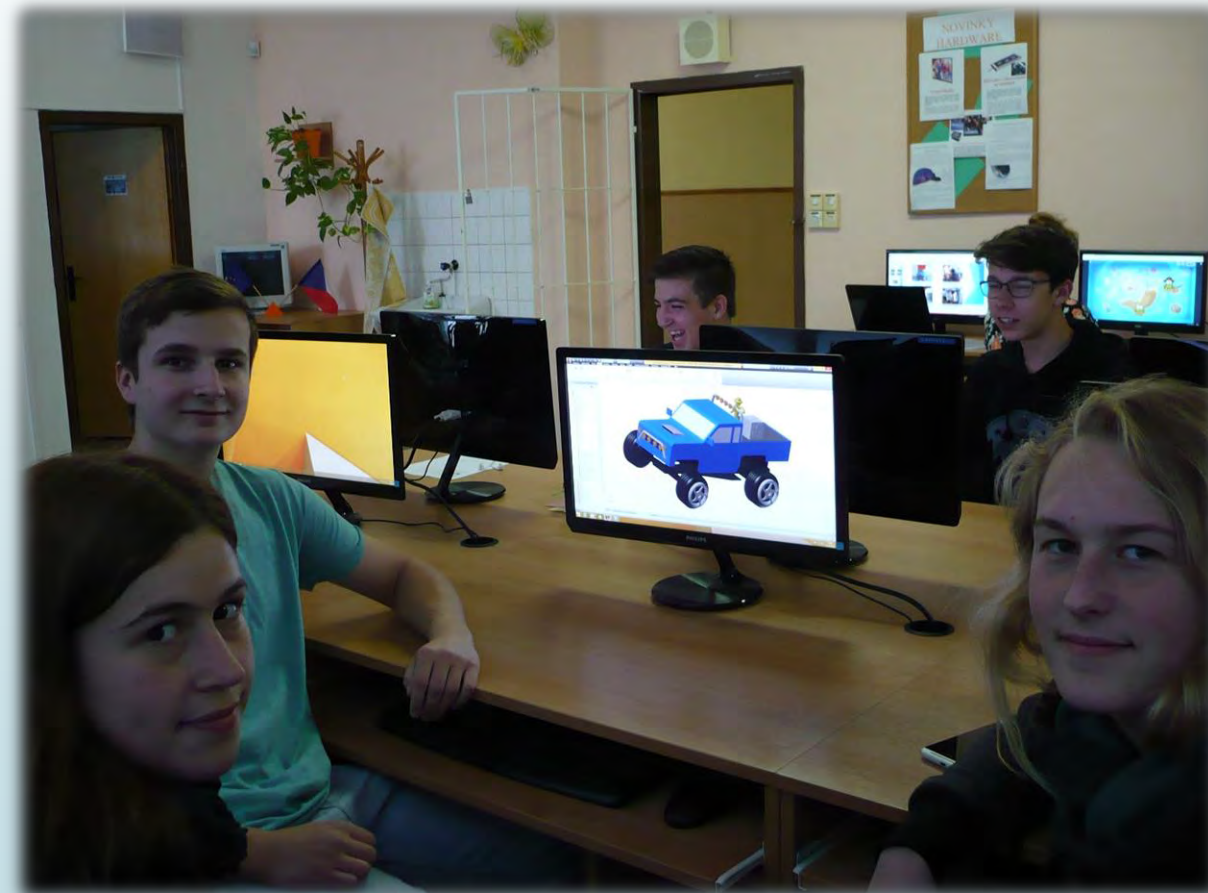

Sheets

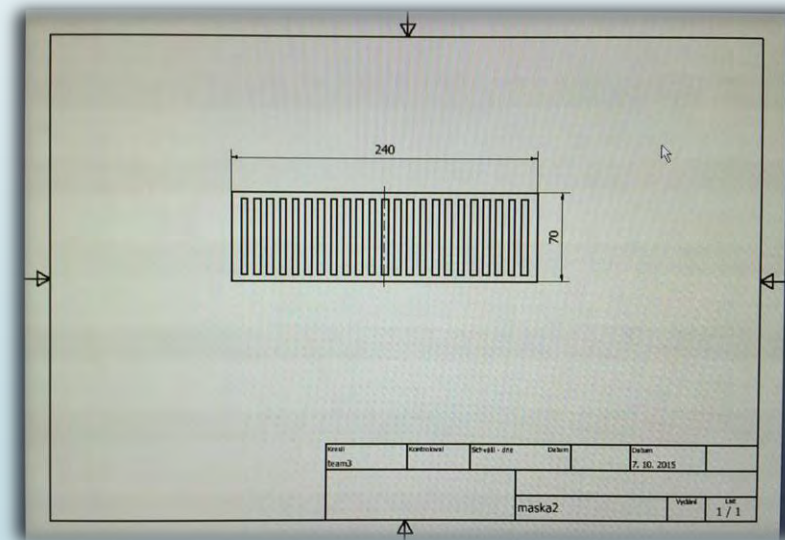
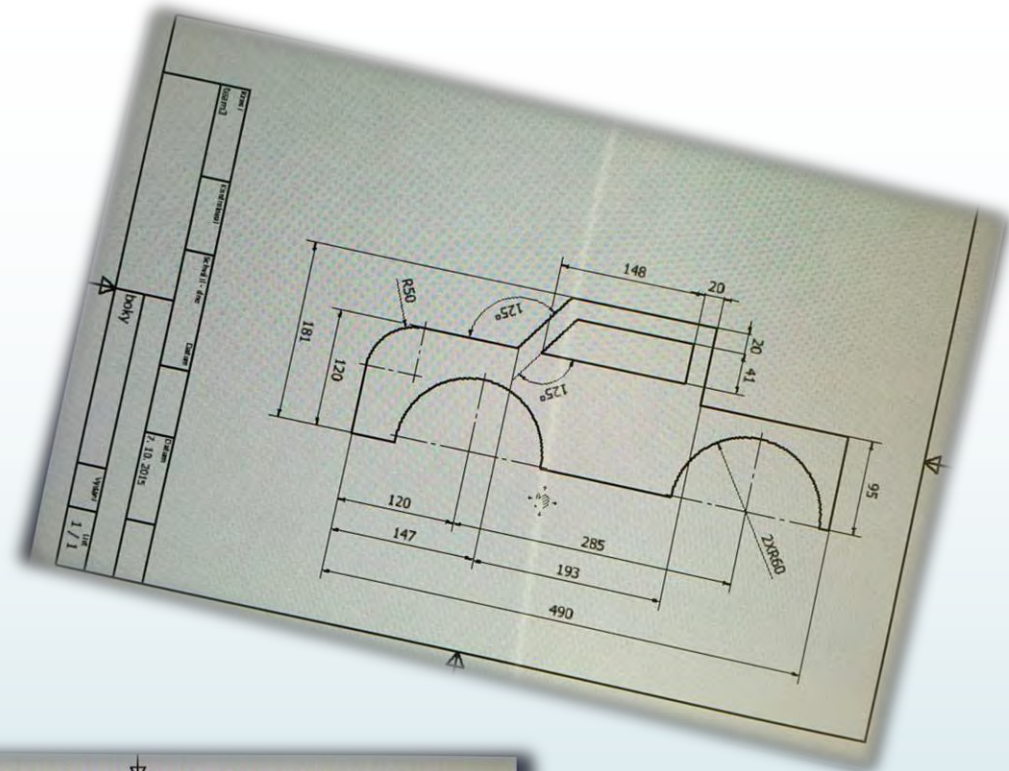
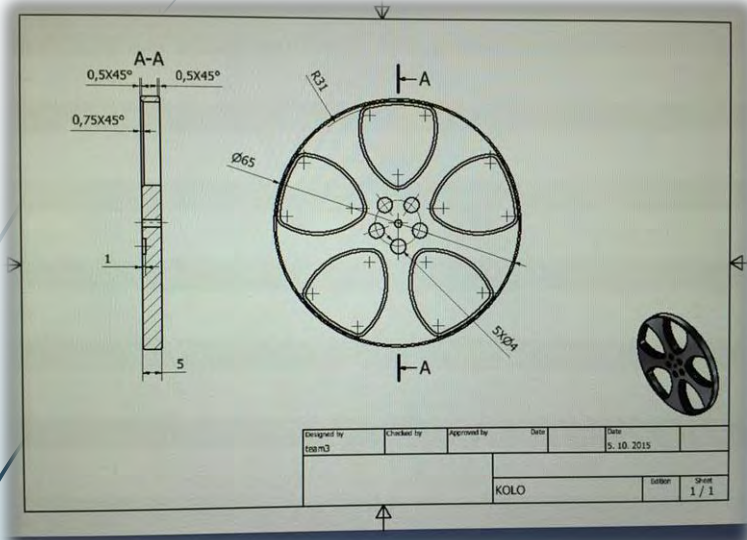

3D

Modelling

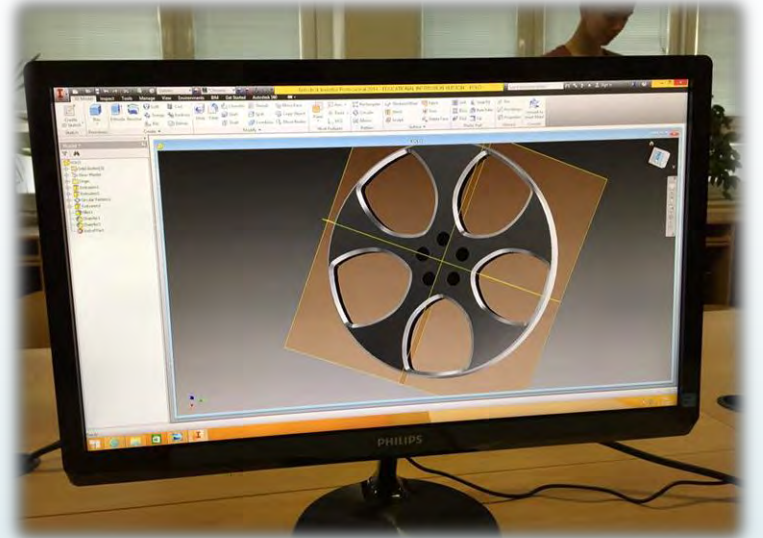

CAD Car model

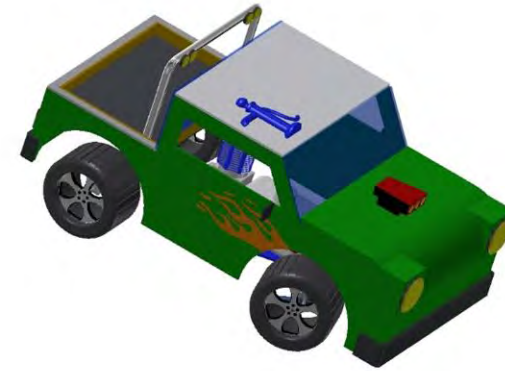



CNC Group

CNC Team photo

Left to right:
Jalůvka Petr;
Sedláček Ondřej;
Hoang Sebastián;
Pohlodko Artur;
Hanák Petr;
Vrba Pavel;
Beppler, Fynn;
Rehorn, Till;
Kainz, Roland

(missing –
Flidr Tomáš;
Holz, Tom)



Their tasks

- ➔ The CNC team has to make programs for the wheel covers and then they have to create them.

The screenshot displays a CNC control interface with the following sections:

- Machine Status:** Stroj, Kanál 1, AUTO, IMPF.DIR TEAM2.MPF
- Program Info:** Kanál aktivní, Program běží, ROV
- Coordinates Table:**

WCS	Pozice	Zb.dráha
+ X	11.466 mm	6.921
- Y	16.485 mm	-10.983
Z	-2.000 mm	0.000
A	0.000 st.	0.000
- Main Spindle (Hlavní vřeteno):**

S1	
Akt.	2000.000 ot/m.
Pož.	2000.000 ot/m.
Pol	0.000 st.
	100.000 %
Výkon [%]	<input type="text"/>
- Current Block (Aktuální blok):** TEAM2.MPF
- Feed Rate (Posuv):**

mm/min	
Akt.	349.940 100.000 %
Pož.	350.000
- Tool (Nástroj):**

► T5	D1	◄
Předvolený nástroj:		
► T5		◄
G03	G42	

How they worked

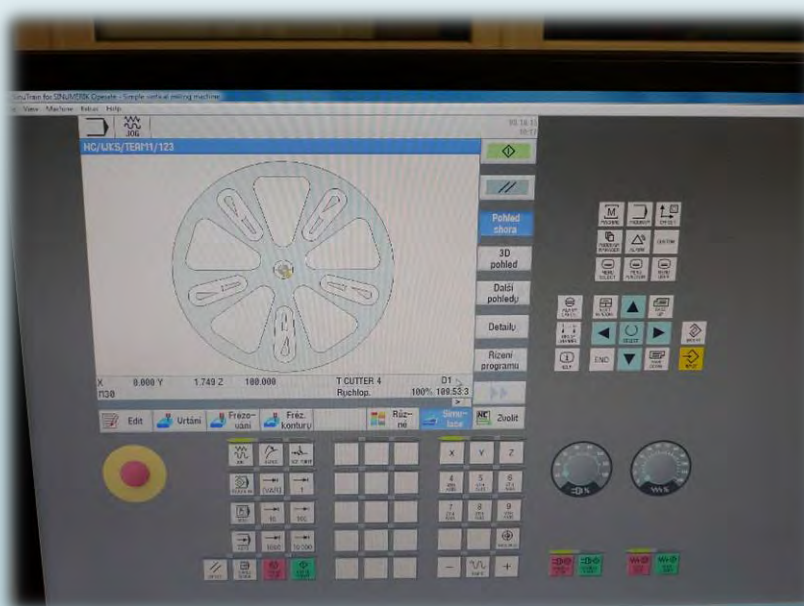
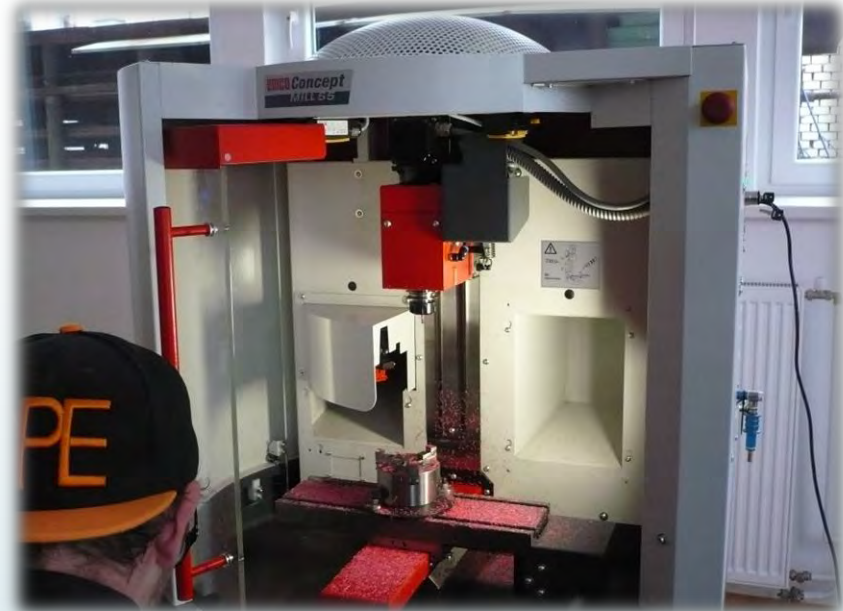
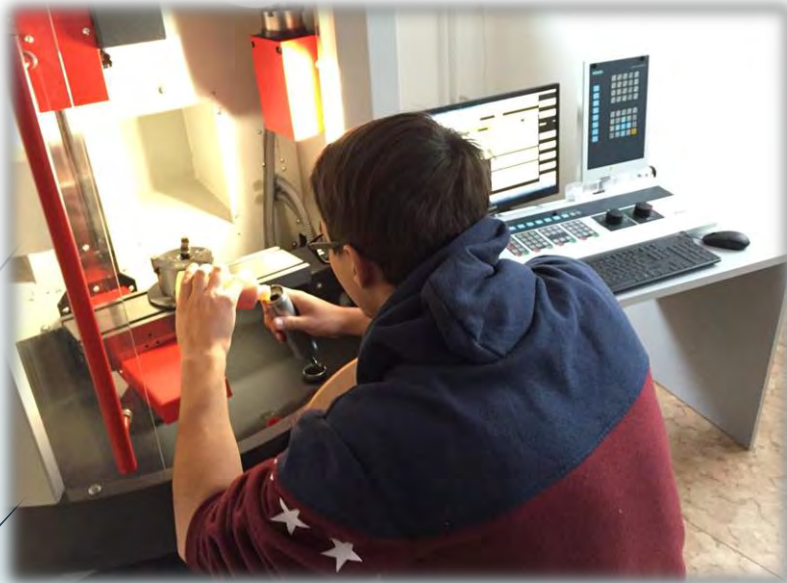

The result

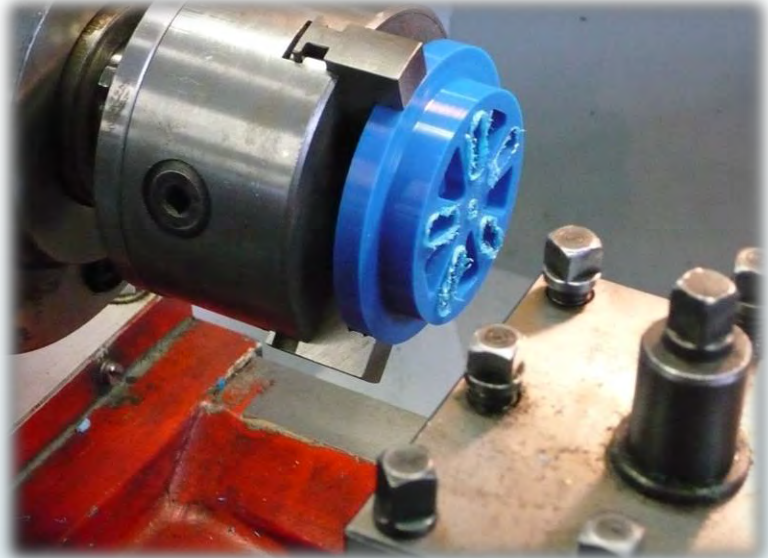



Workshop group

Photos of the workshop



Left to right: Groh, Severin
Hengster, Nicolai



Left to right: Hengster, Nicolai
Groh, Severin
Studený Jaromír

Work being done



Kostík David



Left to right: Mistera Jan, Petrovský Tomáš,



Gröhne, Aaron

Gluing the car body



Colouration of the car bodies



Finishing up



Finished car body

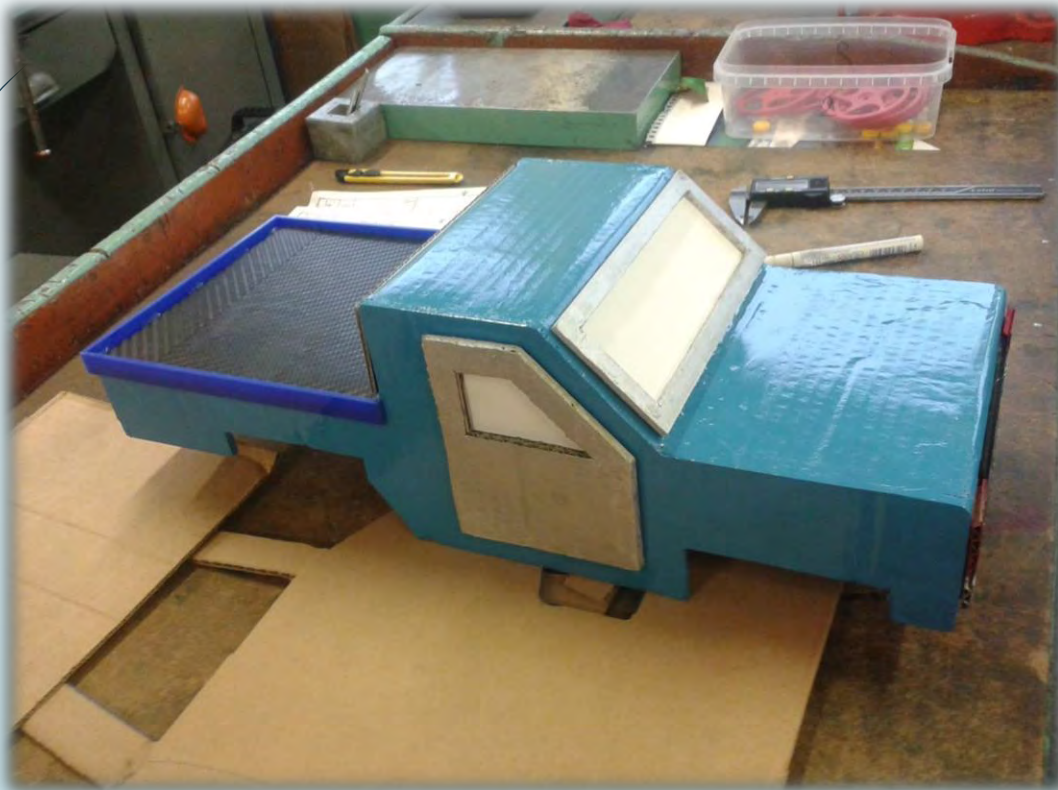



Documentation group

Documentation team photo



Left to right:
Haselman Daniel
Dostál Tomáš
Rada Jan
Švéda Michal
Koehler, Michel
Bayram, Enes
Fanta Jakub-Michael
Masek, Maren
Kouřil Jakub
Stanislav Šesták

(missing:
Hagedorn, Luca)

Their tasks

- ▶ They take care of photographing, communication, presentations of the teams, the team pinboards, daily reports, etc.

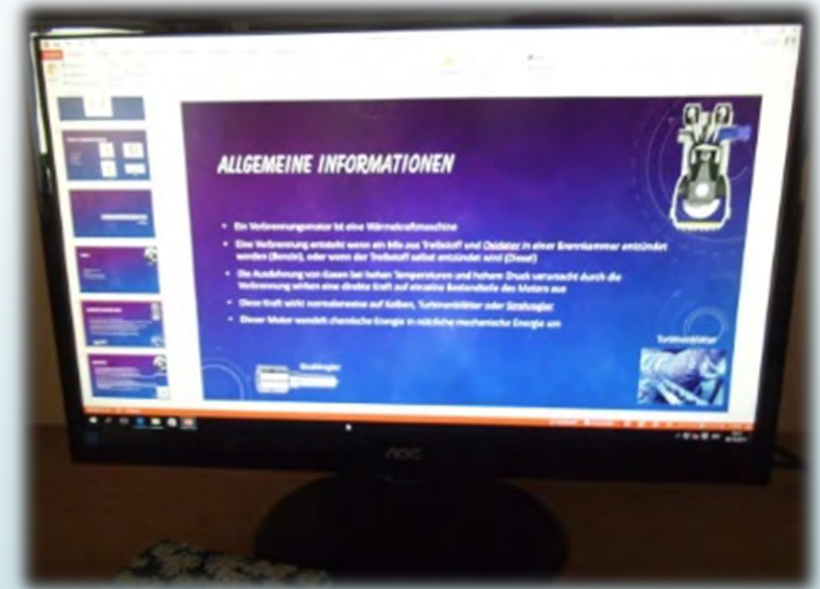

Project documentation



- Our daily duty is to write down everything that happens
- The documentation is written in three languages (English, Czech and German), that means it is important for the Czech and German students to communicate.

Team pinboards



Finished cars



Finished cars

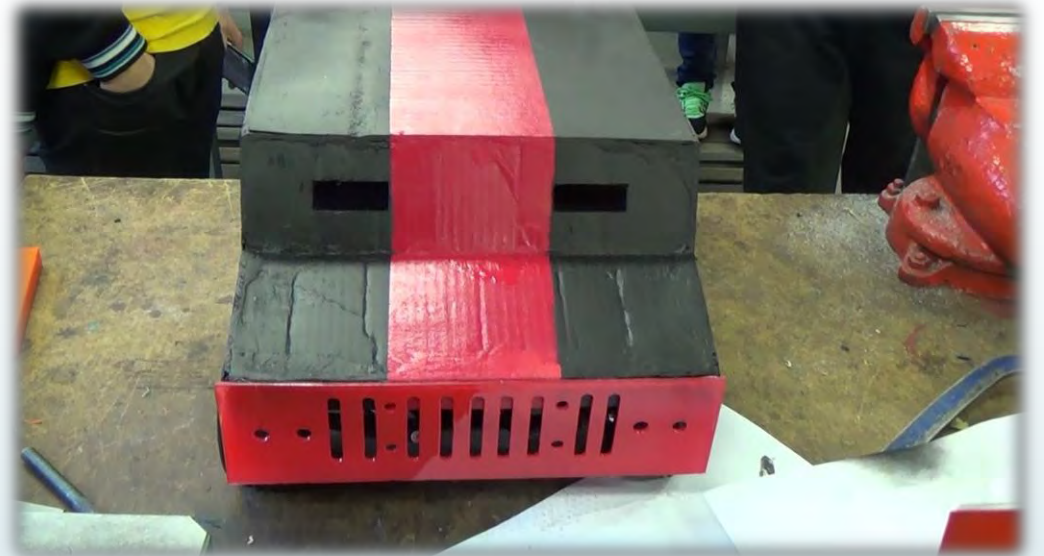



Announcement

Tento projekt byl realizován za finanční podpory Evropské unie. Za obsah publikací (sdělení) odpovídá výlučně autor. Publikace (sdělení) nereprezentují názory Evropské komise a Evropská komise neodpovídá za použití informací, jež jsou jejich obsahem.

This project has been funded with support from the European Commission. This publication [communication] reflects the views only of the author, and the Commission cannot be held responsible for any use which may be made of the information contained therein.

Dieses Projekt wurde mit Unterstützung der Europäischen Kommission finanziert. Die Verantwortung für den Inhalt dieser Veröffentlichung (Mitteilung) trägt allein der Verfasser; die Kommission haftet nicht für die weitere Verwendung der darin enthaltenen Angaben.

Dieses Projekt wurde mit Unterstützung der Europäischen Kommission finanziert.

Die Verantwortung für den Inhalt dieser Veröffentlichung (Mitteilung) trägt allein der Verfasser; die Kommission haftet nicht für die weitere Verwendung der darin enthaltenen Angaben.

Tento projekt byl realizován za finanční podpory Evropské unie. Za obsah publikací (sdělení) odpovídá výlučně autor. Publikace (sdělení) nereprezentují názory Evropské komise. Evropská komise neodpovídá za použití informací, jež jsou jejich obsahem.

This project has been funded with support from the European Commission.

This publication (communication) reflects the views only of the author, and the Commission cannot be held responsible for any use which may be made of the information contained therein.



Erasmus+